

ACOUSTI-SEAL® 900 SERIES TECHNICAL DATA

The Acousti-Seal Paired Panel System.

Paired panel systems are usually the answer for straight-line openings that do not require multiple locations or offset storage. Panels are hinged together in groups of two and provide quick and easy setup. Because one carrier is located in the center of each panel, no auxiliary storage track or support is required. Paired panel systems are ideally suited for applications that require exceptional durability,

acoustic control, and frequent use. Floor-supported paired panels are available for installations where the existing overhead structure cannot support the partition's weight. When not in use, paired panels are designed to be stored at either or both ends of an opening for added storage flexibility. Paired panels are frequently stored in pockets and used to divide classrooms, conference or meeting rooms, and office space.

Modernfold Model

Acousti-Seal 932

Flat Panels, Paired Panel Operation

This specification along with product information and model details can be downloaded from www.modernfold.com

SPECIFICATION - SECTION 10650 OPERABLE PARTITIONS

PART 1 - GENERAL

1.1 RELATED DOCUMENTS

A. Drawings and general provisions of the Contract including General and Supplementary Conditions and Division 1 Specification Sections, apply to this Section.

1.2 SUMMARY

- A. This Section includes the following:
1. Manually operated, paired panel operable partitions.
- B. Related Sections include the following:
1. Division 3 Sections for concrete tolerances required.
 2. Division 5 Sections for primary structural support, including pre-punching of support members by structural steel supplier per operable partition supplier's template.
 3. Division 6 Sections for wood framing and supports, and all blocking at head and jambs as required.
 4. Division 9 Sections for wall and ceiling framing at head and jambs.

1.3 QUALITY ASSURANCE

A. Installer Qualifications: An experienced installer who is certified in writing by the operable partition manufacturer, as qualified to install the manufacturer's partition systems for work similar in material, design, and extent to that indicated for this Project.

B. Acoustical Performance: Test operable partitions in an independent acoustical laboratory in accordance

with ASTM E90 test procedure to attain no less than the STC rating specified. Provide a complete and unedited written test report by the testing laboratory upon request.

C. Preparation of the opening shall conform to the criteria set forth per ASTM E557 "Standard Practice for Architectural Application and Installation of Operable Partitions."

1.4 SUBMITTALS

- A. Product Data: Material descriptions, construction details, finishes, installation details, and operating instructions for each type of operable partition, component, and accessory specified.
- B. Shop Drawings: Show location and extent of operable partitions. Include plans, elevations, sections, details, attachments to other construction, and accessories. Indicate dimensions, weights, conditions at openings, and at storage areas, and required installation, storage, and operating clearances. Indicate location and installation requirements for hardware and track, including floor tolerances required and direction of travel. Indicate blocking to be provided by others.
- C. Setting Drawings: Show imbedded items and cutouts required in other work, including support beam punching template.
- D. Samples: Color samples demonstrating full range of finishes available by architect. Verification samples will be available in same thickness and material indicated for the work.

1.5 DELIVERY, STORAGE, AND HANDLING

A. Clearly mark packages and panels with numbering

ACOUSTI-SEAL® 900 SERIES TECHNICAL DATA

systems used on Shop Drawings. Do not use permanent markings on panels.

- B. Protect panels during delivery, storage, and handling to comply with manufacturer's direction and as required to prevent damage.

1.6 WARRANTY

- A. Provide written warranty by manufacturer of operable partitions agreeing to repair or replace any components with manufacturing defects.
B. Warranty period: Two (2) years from date of shipment.

PART 2 – PRODUCTS

2.1 MANUFACTURERS, PRODUCTS, AND OPERATION

- A. Manufacturers: Subject to compliance with requirements, provide products by the following:
1. Modernfold, Inc.
B. Products: Subject to compliance with the requirements, provide the following product:
1. Acousti-Seal #932 manually operated paired panel operable partition.

2.2 OPERATION

- A. Acousti-Seal #932: Series of paired flat panels hinged together in pairs, manually operated, top supported with operable floor seals.
B. Final Closure (select one):
1. Horizontally expanding panel edge with removable crank
2. Hinged panel closure
3. Angle Jamb
4. Pass door closure
5. Spinner panel

2.3 PANEL CONSTRUCTION

- A. Nominal 3-inch (76mm) thick panels in manufacturer's standard 48-inch (1220mm) widths. All panel horizontal and vertical framing members fabricated from minimum 18-gauge formed steel with overlapped and welded corners for rigidity. Top channel is reinforced to support suspension system components. Frame is designed so that full vertical edges of panels are of formed steel and provide concealed protection of the edges of the panel skin.
B. Panel Skin Options:
1. 0.50-inch (13mm) tackable fire core C gypsum board, class "A" rated single material or

composite layers continuously bonded to panel frame. Acoustical ratings of panels with this construction (select one):

- a. 41 STC
b. 47 STC
c. 50 STC
2. 0.50-inch (13mm) tackable moisture resistant gypsum board, class "A" rated single material or composite layers continuously bonded to panel frame. Acoustical ratings of panels with this construction (select one):
a. 41 STC
b. 47 STC
c. 50 STC
3. 0.50-inch (13mm) medium density fiberboard, single material or composite layers continuously bonded to panel frame. Acoustical ratings of panels with this construction (select one):
a. 41 STC
b. 47 STC
c. 50 STC
4. Nominal 21-gauge roll-formed steel wrapping around panel edge. Panel skins shall be lock formed and welded directly to the frame for unitized construction. Acoustical ratings of panels with this construction (select one):
a. 28 STC
b. 45 STC
c. 50 STC
d. 52 STC
C. Hinges for Panels, Closure Panels, Pass Doors, and Pocket Doors shall be (select one):
1. Full leaf butt hinges, attached directly to panel frame with welded hinge anchor plates within panel to further support hinge mounting to frame. Hinges mounted into panel edge or vertical astragal are not acceptable.
2. SOSS® Invisible laminated hinge with antifriction segments mounted between each heat treated link. Hinge to be attached directly to panel frame. Welded internal hinge bracket shall support the hinge and allow for adjustment of hinge plates. Concealed hinges mounted into panel edge or vertical astragal are not acceptable.
(Available on steel skin panel only)
D. Panel Trim: No vertical trim required or allowed on edges of panels; minimal groove appearance at panel joints.
E. Panel Weights:
Non-Steel Skin
1. 41 STC – 6.5 lbs./square foot
2. 47 STC – 7 lbs./square foot
3. 50 STC – 8 lbs./square foot

ACOUSTI-SEAL® 900 SERIES TECHNICAL DATA

Steel Skin

1. 28 STC – 6 lbs./square foot
2. 45 STC – 8 lbs./square foot
3. 50 STC – 8 lbs./square foot
4. 52 STC – 11 lbs./square foot

2.4 PANEL FINISHES

- A. Panel Finish: Factory applied, Class "A" rated material. Finish shall be (select as appropriate):
1. Reinforced vinyl with woven backing weighing not less than 15 ounces per lineal yard.
 2. Reinforced heavy duty vinyl with woven backing weighing not less than 27 ounces per lineal yard.
 3. Acoustical, non-woven needle punch carpet, with fused fibers to prevent unraveling or fray of material.
 4. Wall covering and upholstery fabric weighing not less than 12 ounces per lineal yard, with surface treatment to resist stains.
 5. Customer's own material (subject to factory approval).
 6. Full height tackboard with vinyl or fabric covering.
 - a. 0.25-inch natural cork
 - b. 0.25-inch fiber board tackbase
 7. Full height steel work surfaces (chalkboard or dry marker board).
 8. High pressure plastic laminate on MDF board.
 9. Wood veneer on MDF board.
 10. Reconstituted wood veneer (FormWood) on steel skin.
 11. Uncovered for field finishing.
 12. Primed for field finishing.
- B. Panel Trim: Exposed panel trim of one consistent color (Smoke Gray or Dark Bronze).

2.5 SOUND SEALS

- A. Vertical Interlocking Sound Seals between panels: Roll-formed steel astragals, with reversible tongue and groove configuration in each panel edge for universal panel operation. Rigid plastic astragals or astragals in only one panel edge are not acceptable.
- B. Horizontal Top Seals: Continuous contact extruded vinyl bulb shape with pairs of non-contacting vinyl fingers to prevent distortion without the need for mechanically operated parts.
- C. Horizontal Bottom Seals shall be (select one):
1. Modernfold IA2 Bottom seal. Automatic operable seals providing nominal 2-inch (51mm) operating clearance with an operating range of +0.50-inch

(13mm) to -1.50-inch (38mm) which automatically drop as panels are positioned, without the need for tools or cranks.

2. Modernfold IM2 Bottom Seal. Manually activated bottom seals with self contained handle providing nominal 2-inch (51mm) operating clearance with an operating range of +0.50-inch (13mm) to -1.50-inch (38mm). Seal shall be operable from panel edge or face.
3. Modernfold IC2 Bottom Seal. Manually activated operable bottom seals with removable handle providing nominal 2-inch (51mm) operating clearance with an operating range of +0.50-inch (13mm) to -1.50-inch (38mm). Seal shall be operable from panel edge or face.

2.6 SUSPENSION SYSTEM (select one)

- A. #17 Suspension System
1. Suspension Tracks: Minimum 11-gauge, 0.12-inch (3.04mm) roll-formed steel track, suitable for either direct mounting to a wood header or supported by adjustable steel hanger brackets, supporting the load-bearing surface of the track, connected to structural support by pairs of 0.38-inch (10mm) diameter threaded rods. Aluminum track is not acceptable.
 - a. Exposed track soffit: Steel, integral to track, and pre-painted off-white.
 2. Carriers: One all-steel trolley with steel tired ball bearing wheels per panel (except hinged panels). Non-steel tires are not acceptable.

- OR -

B. #860 Suspension System

1. Suspension Tracks: Heat-treated extruded aluminum. Track to be supported by adjustable steel hanger brackets connected to structural support by pairs of 0.38-inch (10mm) diameter threaded rods.
 - a. Exposed track soffit: Aluminum, integral to track, and pre-painted off-white.
2. Carriers: Shall have horizontal counter-rotating wheels with precision ground steel ball bearings.

- OR -

C. #25 Suspension System

1. Suspension Tracks: Heat-treated extruded aluminum. Track to be supported by adjustable steel hanger brackets connected to structural

ACOUSTI-SEAL® 900 SERIES TECHNICAL DATA

support by pairs of 0.38-inch (10mm) diameter threaded rods.

a. Exposed track soffit: Aluminum, integral to track, and pre-painted off-white.

2. Carriers: Shall have four precision roller bearing trolley wheels with polymer guide rollers for smooth operation.

- OR -

D. #14 Suspension System

1. Suspension Tracks: Minimum 7-gauge, 0.18-inch (4.57mm) roll formed steel. Static loading of track with brackets at 48-inch (1220mm) centers shall show no failure of track or brackets at 5,000 pounds (2550kg) point loading at mid-span. Track shall be supported by adjustable steel hanger brackets connected to structural support pairs of 0.50-inch (13mm) diameter threaded rods.

Brackets must support the load bearing surface of the track.

a. Exposed track soffit: Steel, removable for service and maintenance, attached to track bracket without exposed fasteners, and pre-painted off-white.

2. Carriers: One all-steel trolley with steel tired ball bearing wheels per panel (except hinged panels). Non-steel tires are not acceptable.

2.7 OPTIONS

A. Single Pass Doors (select one):

1. Standard hollow metal door hung in a steel frame. ADA compliant pass door to be equipped with friction latch and flush pulls for panic operation. No threshold will be permitted.

a. Pass door to be prime painted for field finishing.
b. Pass door to be painted dark bronze or smoke gray.

2. Matching pass door same thickness and appearance as panels. ADA compliant pass door to be trimless and equipped with friction latch and flush pulls for panic operation. No threshold will be permitted.

B. Work Surfaces:

1. Tackboard: Minimum 0.25-inch (6.35mm) natural cork, covered with vinyl or fabric, with horizontal trim without exposed fasteners. Trim is not acceptable on vertical edges.

2. Dry-erase Markerboard: White enamel on steel, bonded to the face of the panel with horizontal trim without exposed fasteners. Trim is not acceptable on vertical edges to provide

uninterrupted work surface.

3. Chalkboard: Porcelain enamel on steel, bonded to the face of the panel with horizontal trim without exposed fasteners. Trim is not acceptable on vertical edges to provide uninterrupted work surface.

C. Available Accessories/Options:

1. Pocket Doors: Acousti-Seal Pocket Doors by Modernfold, Inc., with same construction, finish, and appearance as the adjacent panels.

2. Finished end caps.

3. Intersecting partition interface.

4. Automatic door closures.

5. Self-Illuminated exit signs.

6. Inset window options - glazed or unglazed.

7. Panic hardware.

PART 3 – EXECUTION

3.1 INSTALLATION

A. General: Comply with ASTM E557, operable partition manufacturer's written installation instructions, Drawings and approved Shop Drawings.

B. Install operable partitions and accessories after other finishing operations, including painting have been completed.

C. Match operable partitions by installing panels from marked packages in numbered sequence indicated on Shop Drawings.

D. Broken, cracked, chipped, deformed or unmatched panels are not acceptable.

3.2 CLEANING AND PROTECTION

A. Clean partition surfaces upon completing installation of operable partitions to remove dust, dirt, adhesives, and other foreign materials according to manufacturer's written instructions.

B. Provide final protection and maintain conditions in a manner acceptable to the manufacturer and installer that insure operable partitions are without damage or deterioration at time of Substantial Completion.

3.3 ADJUSTING

A. Adjust operable partitions to operate smoothly, easily, and quietly, free from binding, warp, excessive deflection, distortion, nonalignment, misplacement, disruption, or malfunction, throughout entire operational range. Lubricate hardware and other moving parts.

ACOUSTI-SEAL® 900 SERIES TECHNICAL DATA

3.4 EXAMINATION

A. Examine flooring, structural support, and opening, with Installer present, for compliance with requirements for installation tolerances and other conditions affecting performance of operable partitions. Proceed with installation only after unsatisfactory conditions have been corrected.

3.5 DEMONSTRATION

- A. Demonstrate proper operation and maintenance procedures to Owner's representative.
- B. Provide Operation and Maintenance Manual to Owner's representative.

STC CONSTRUCTION AND TRACK SYSTEM HEIGHT LIMITATIONS

Acousti-Seal 932	Non-Steel Skin Max Height			Welded Steel Skin Max Height			
	41 STC	47 STC	50 STC	28 STC	45 STC	50 STC	52 STC
#17 Direct Mounted Track	14'-2"	12'-2"	10'-2"	14'-2"	10'-2"	10'-2"	
#17 Bracket Mounted Track	18'-2"	18'-2"	16'-2"	18'-2"	16'-2"	16'-2"	12'-2"
#17 Hidden Track	18'-2"	18'-2"	16'-2"	18'-2"	16'-2"	16'-2"	12'-2"
#14 Bracket Mounted Track	18'-2"	18'-2"	18'-2"	18'-2"	18'-2"	18'-2"	18'-2"
#25 Bracket Mounted Track	18'-2"	18'-2"	18'-2"	18'-2"	18'-2"	18'-2"	18'-2"
#860 Bracket Mounted Track	16'-2"	16'-2"	16'-2"	16'-2"	16'-2"	16'-2"	14'-2"

ACOUSTI-SEAL® 900 SERIES TECHNICAL DATA STEEL SKIN PANEL CONSTRUCTION

Acousti-Seal 932 Panel Section Frame Details

PANEL DETAILS ARE NOT TO SCALE

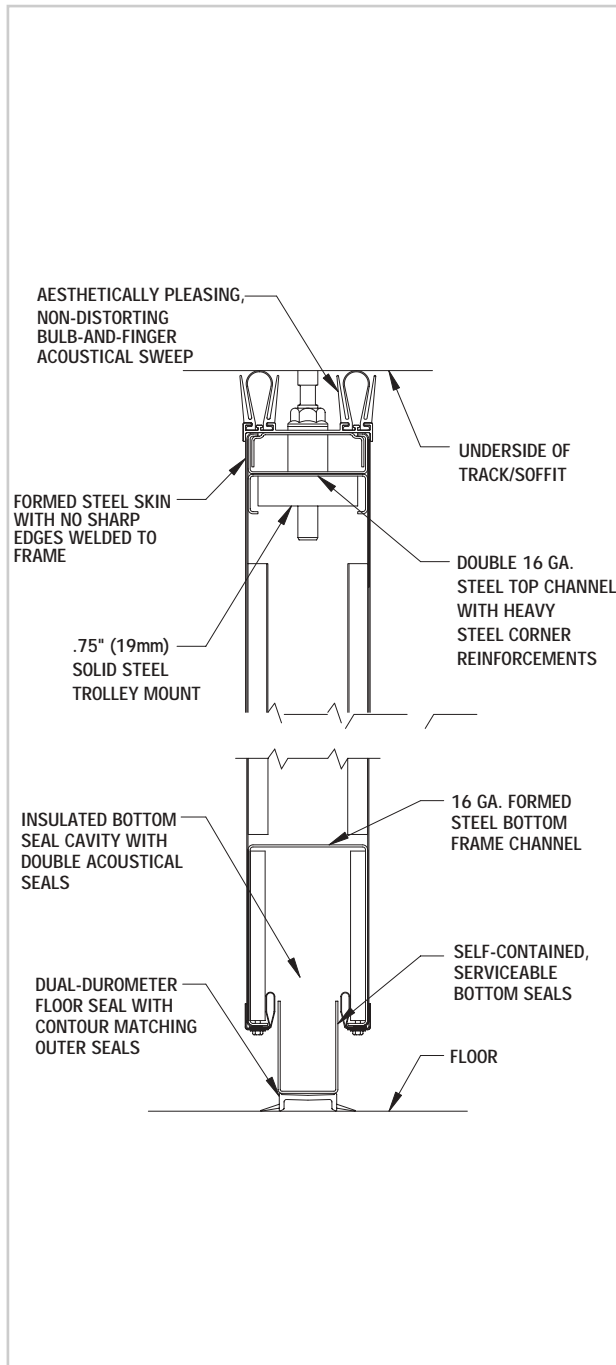

Acousti-Seal 932 Standard Panel Joint

Roll-formed skin wraps completely around the edge of vertical 16 ga. steel channel and is locked in place, eliminating any sharp edges and creating a unitized panel. The outer covering is secured under the steel astragal to prevent peeling.

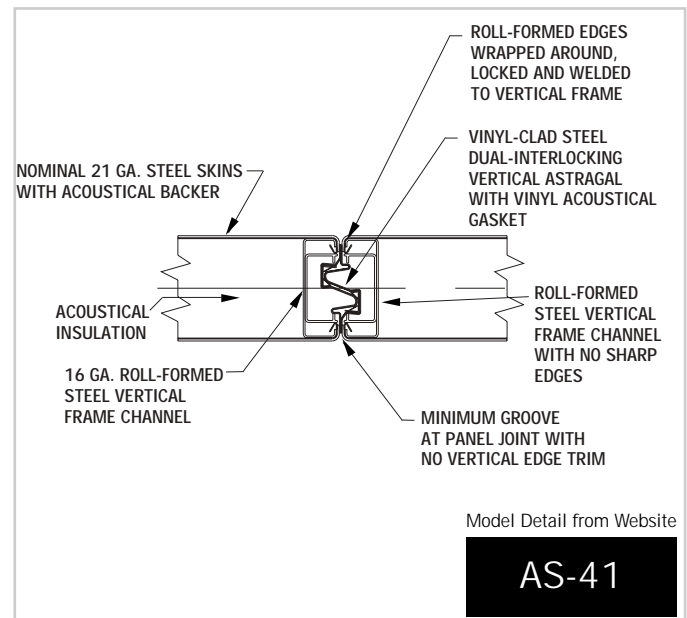

Heavy steel hinges are mounted directly to the center of the vertical frame channel, not simply on the outside edge of the panel. Steel plates on the back of the channel prevent buckling or bending and provide the strongest hinged connection.

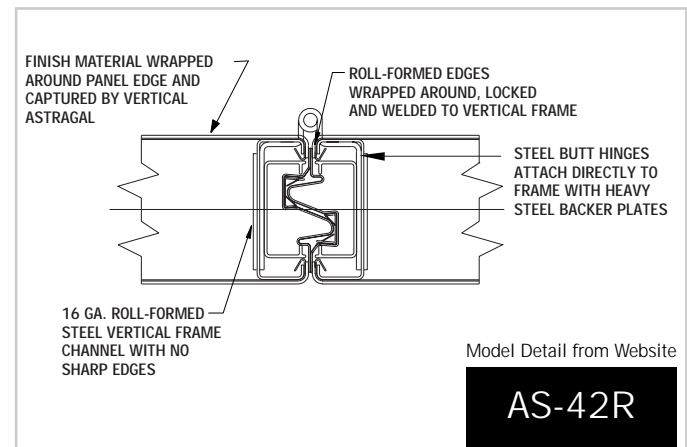

ACOUSTI-SEAL® 900 SERIES TECHNICAL DATA NON-STEEL SKIN PANEL CONSTRUCTION

Acousti-Seal 932 Panel Section Frame Details

PANEL DETAILS ARE NOT TO SCALE

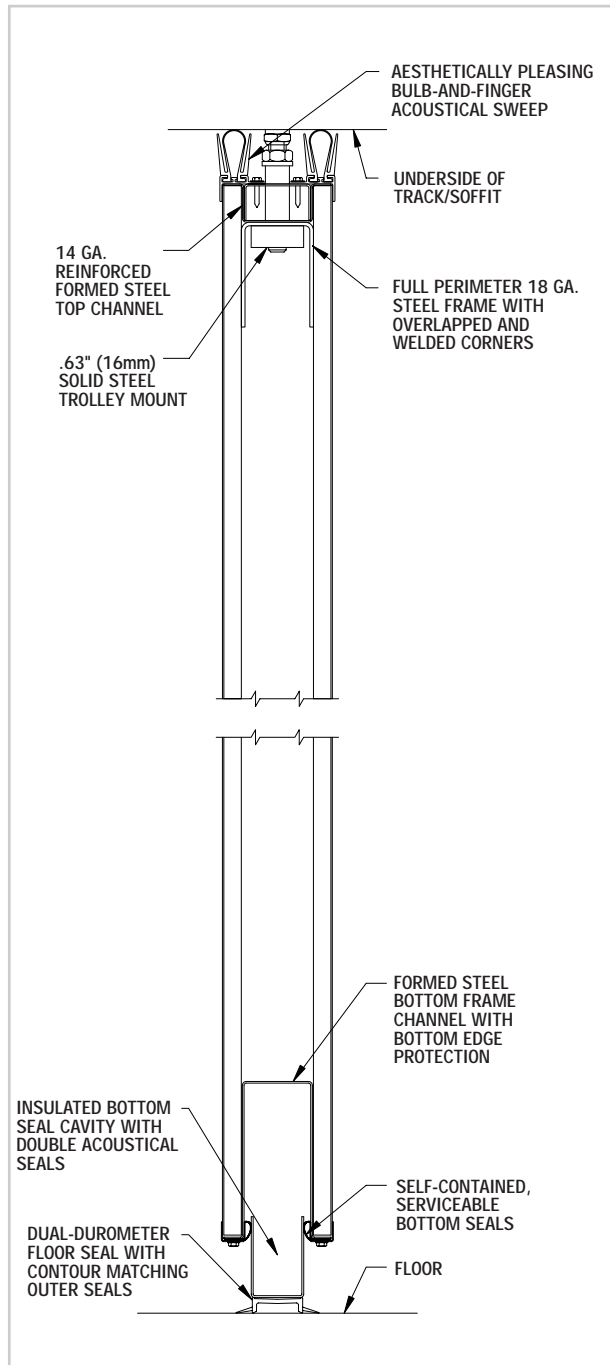

Acousti-Seal 932 Standard Panel Joint

Roll-formed vertical frame channel provides added strength while eliminating any sharp edges. The outer covering is secured under the steel astragal to prevent peeling. The complete vertical edge of the panel is steel for maximum durability.

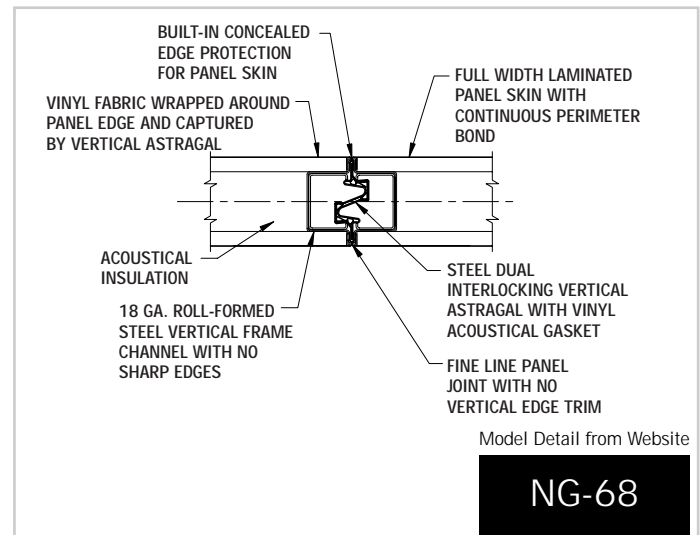

Heavy steel hinges are mounted directly to the center of the vertical frame channel, not simply on the outside edge of the panel. Steel plates on the back of the channel prevent buckling or bending and provide the strongest hinge connection.

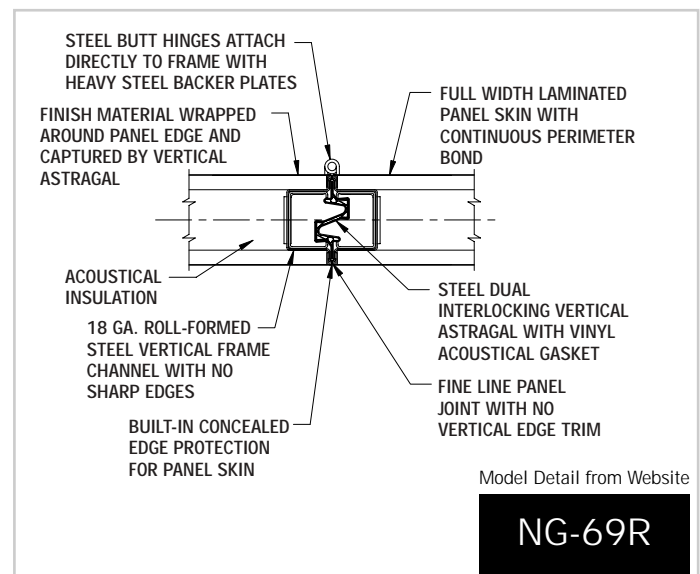

ACOUSTI-SEAL® 900 SERIES TECHNICAL DATA SUSPENSION SYSTEM OPTIONS

#17 Track System Direct Mount

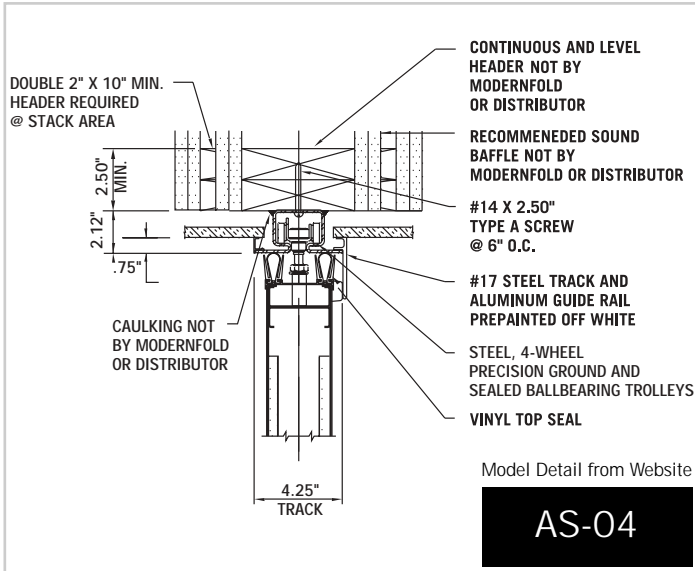

#17 Track System Bracket Mount

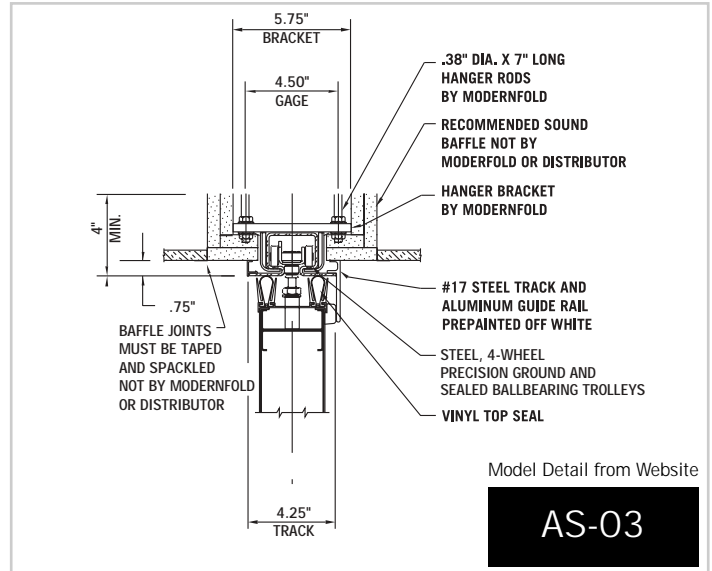

#14 Track System Bracket Mount

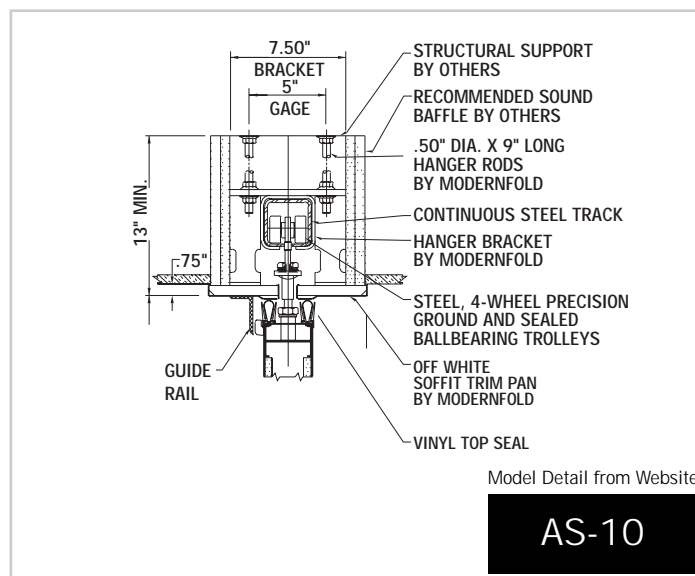

ACOUSTI-SEAL® 900 SERIES TECHNICAL DATA SUSPENSION SYSTEM OPTIONS

#25 Track System Bracket Mount

#860 Track System Bracket Mount

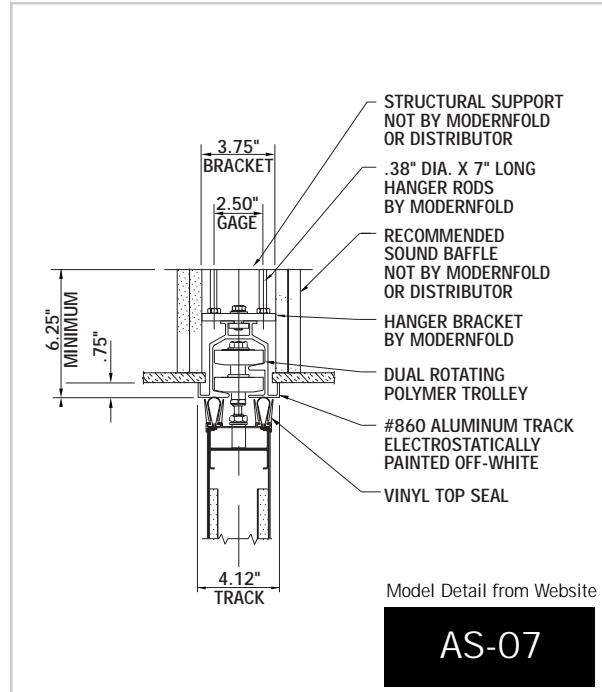
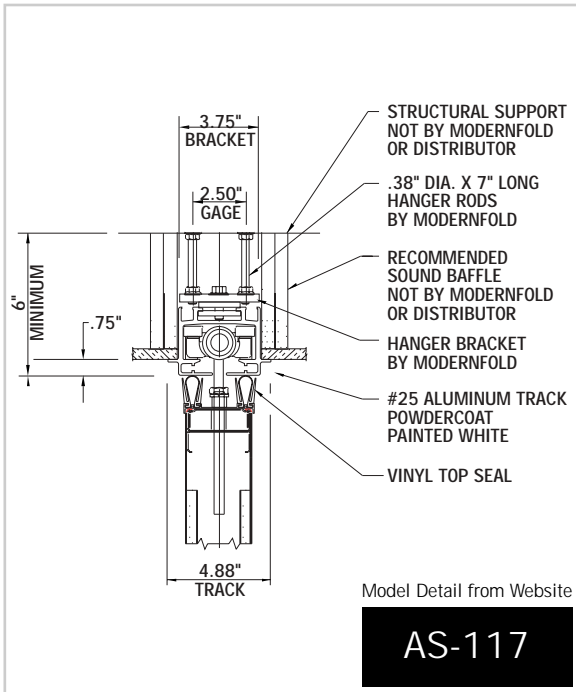

ACOUSTI-SEAL® 900 SERIES TECHNICAL DATA PANEL, WORK SURFACE, AND PASS DOOR OPTIONS

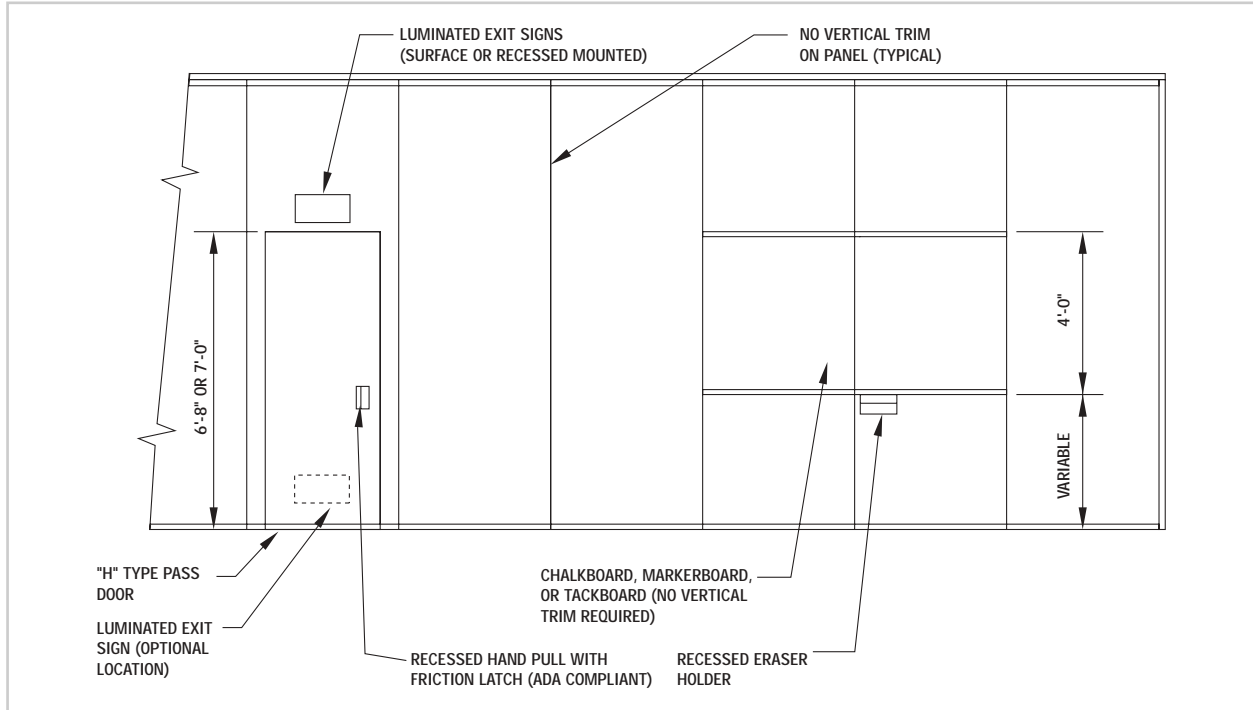

FLOOR SEAL OPTIONS

2" Automatic Seal

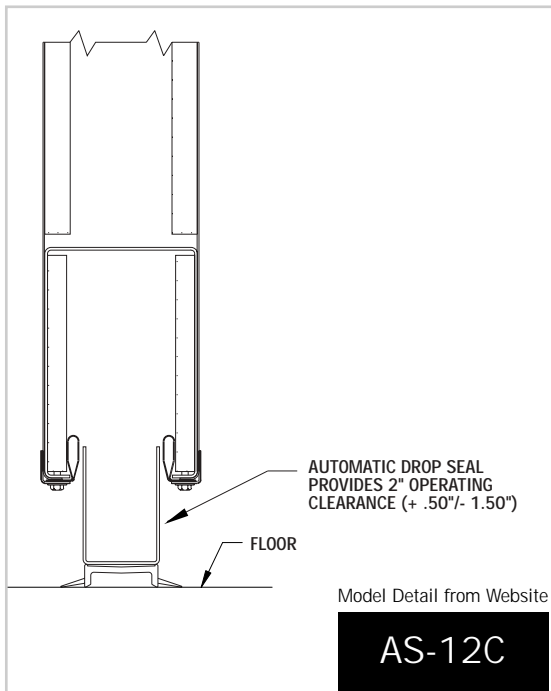

2" Manual Seal

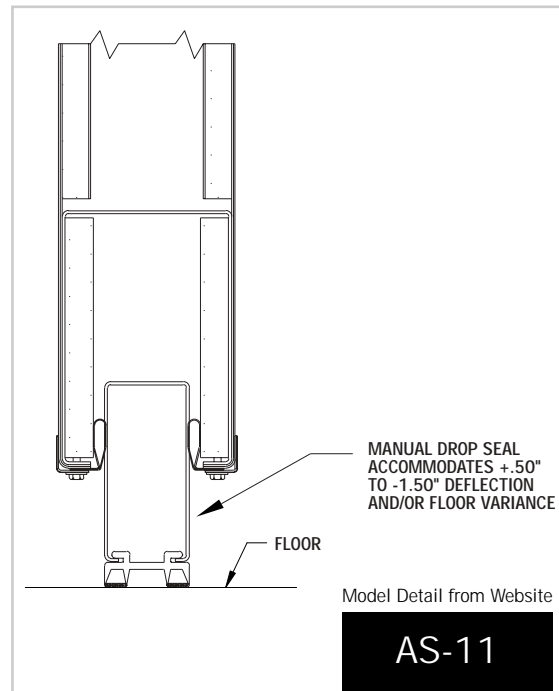

ACOUSTI-SEAL® 900 SERIES TECHNICAL DATA POCKET ENCLOSURE AND STACKING OPTIONS

Expandable Jamb Closure -
Even Panel Quantity

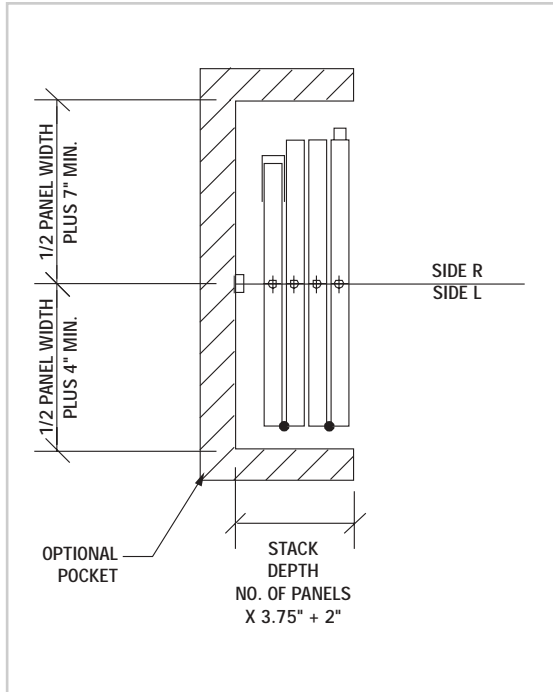

Expandable Jamb Closure -
Odd Panel Quantity

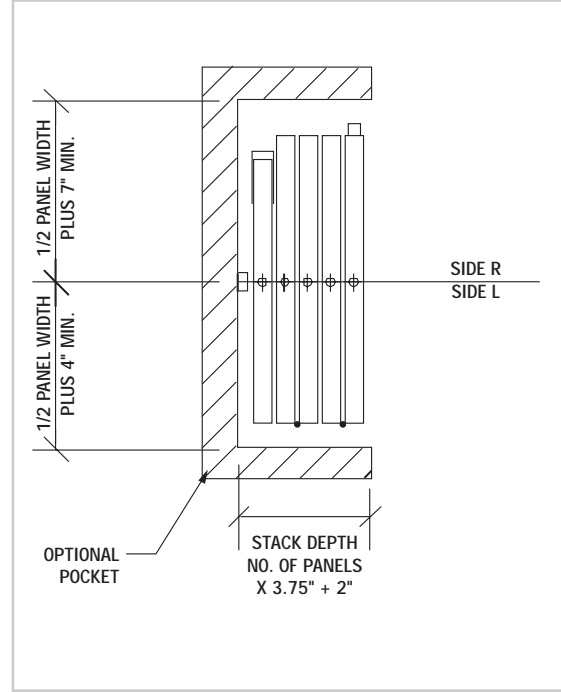

Remote Expandable Jamb Closure

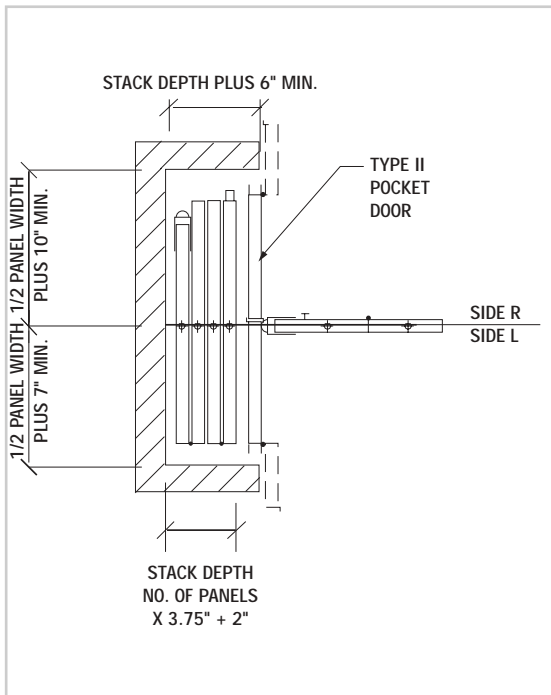

Angle Jamb Closure -
Odd Panel Quantity

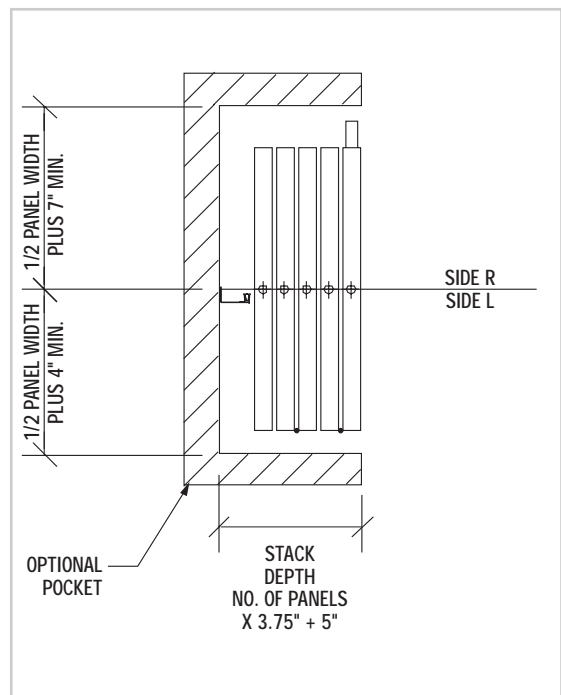

ACOUSTI-SEAL® 900 SERIES TECHNICAL DATA POCKET ENCLOSURE AND STACKING OPTIONS

Angle Jamb Closure -
Even Panel Quantity

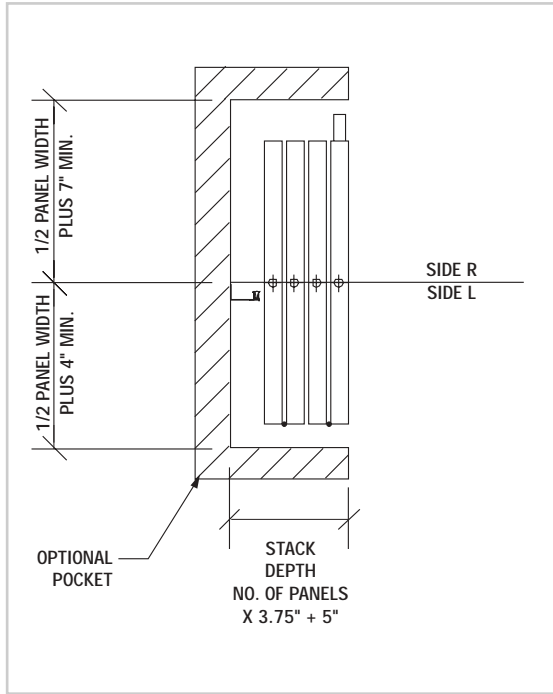

Pass Door Closure

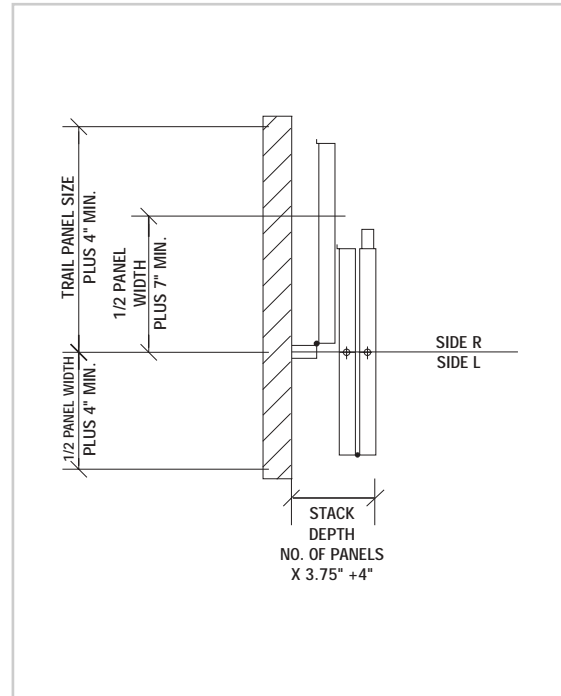

Bi-fold Hinged Panel Closure

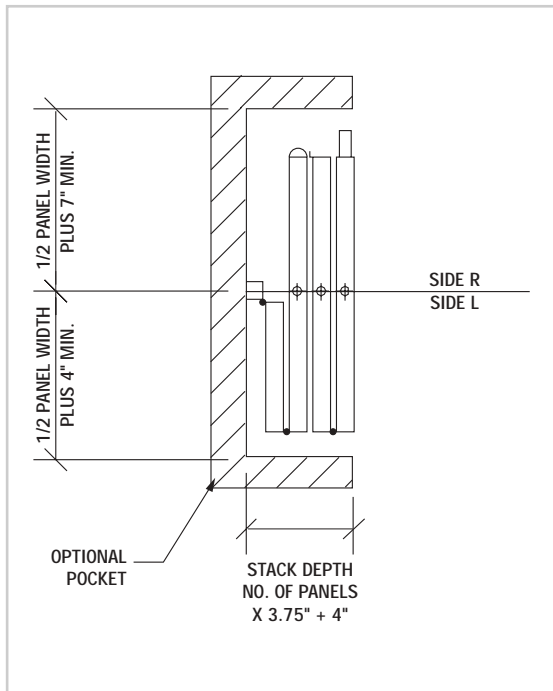

Single Hinged Panel Closure

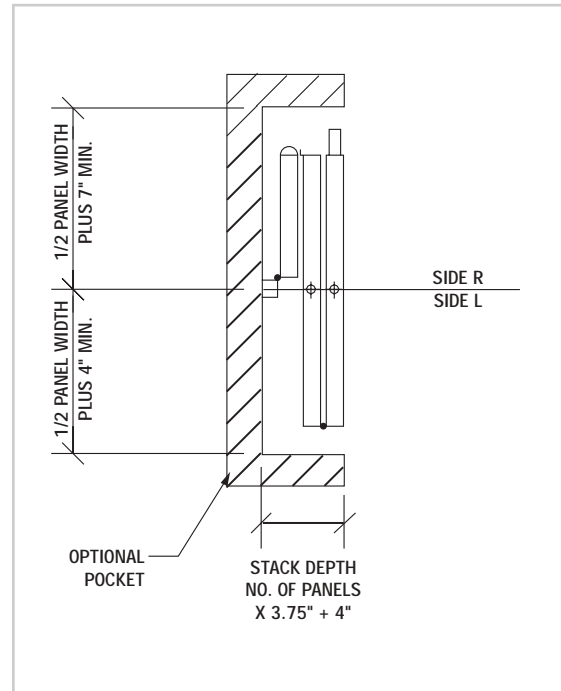

ACOUSTI-SEAL® 900 SERIES TECHNICAL DATA PANEL CROSS SECTIONS

Hinged Jamb

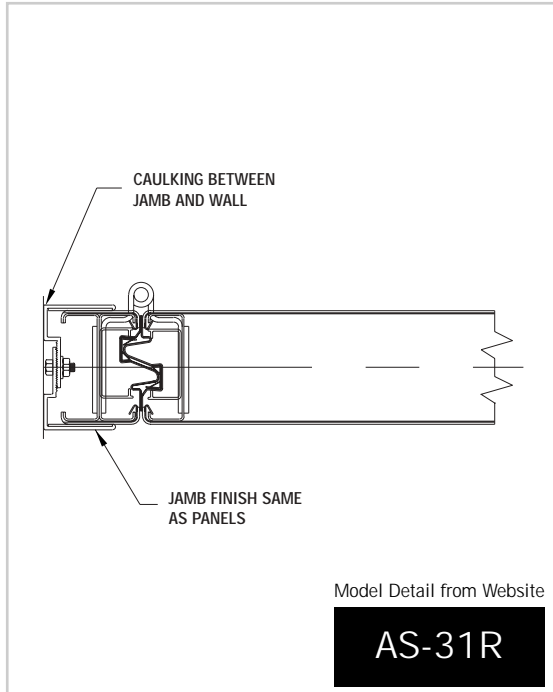

Expandable Panel w/ Jamb

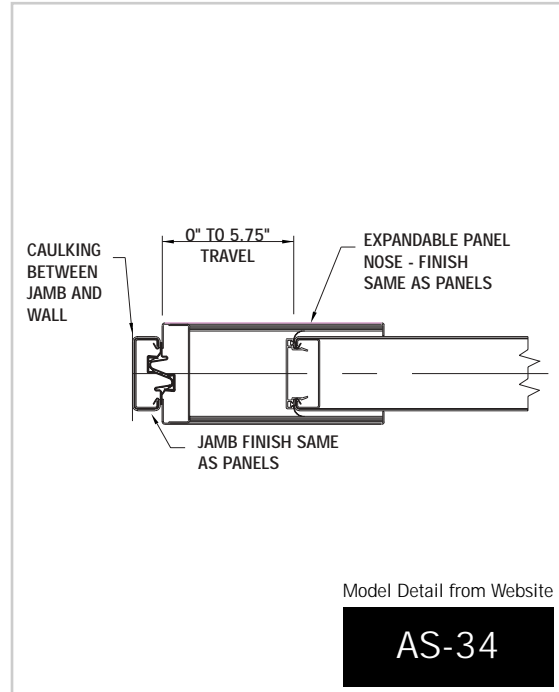

Expandable Panel w/ Bulb Seal

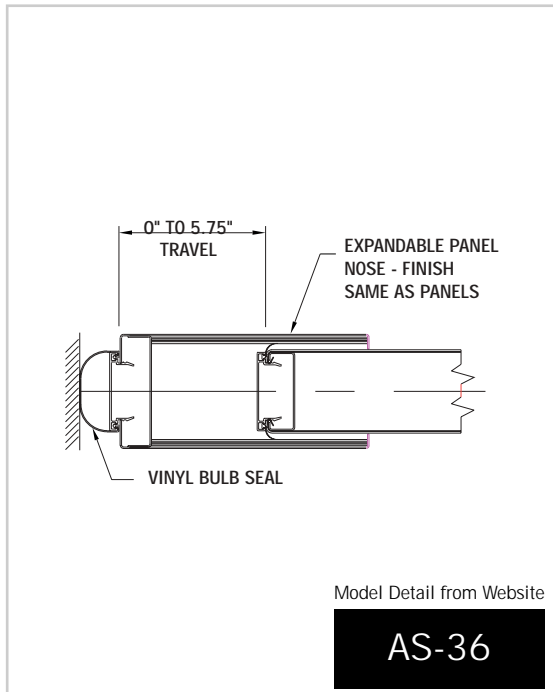

Angle Jamb

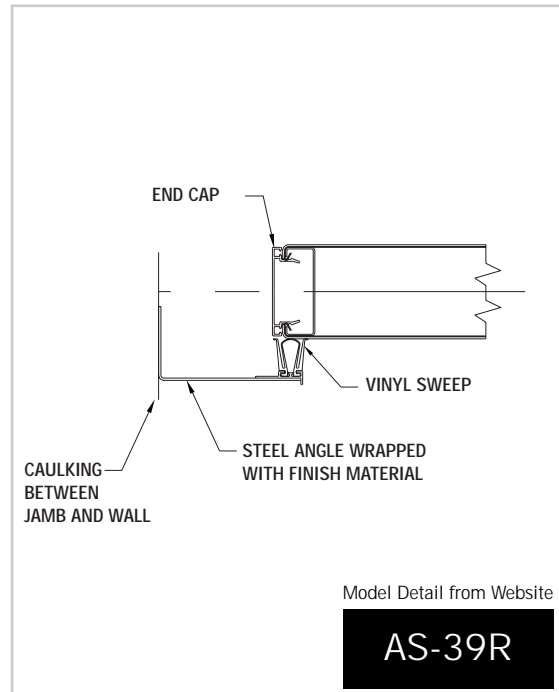

ACOUSTI-SEAL® 900 SERIES TECHNICAL DATA PANEL CROSS SECTIONS

Hinged Panel Meeting w/ Bulb Seal

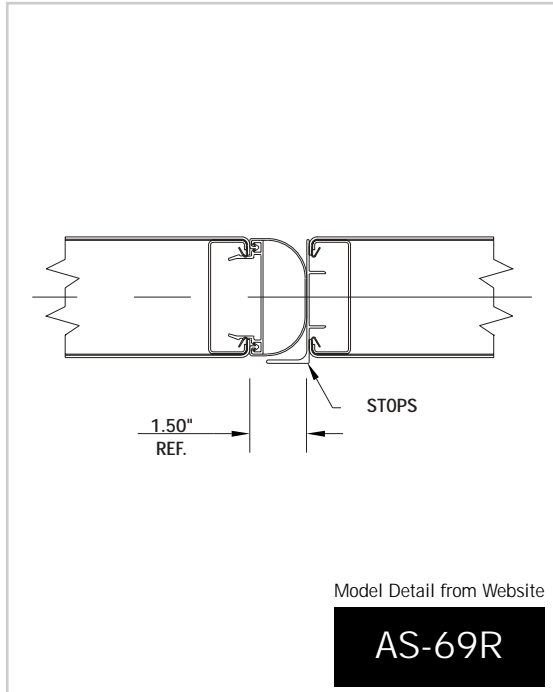

Hinged Panel Meeting
w/ Pass Door Astragal

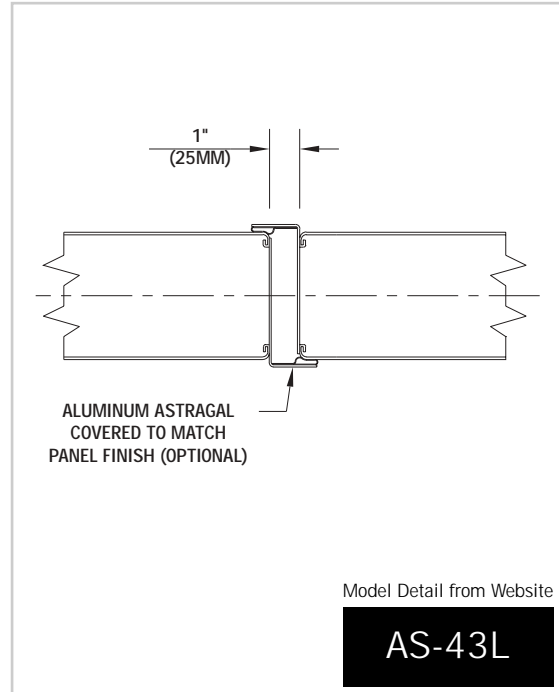

Standard Panel Joint

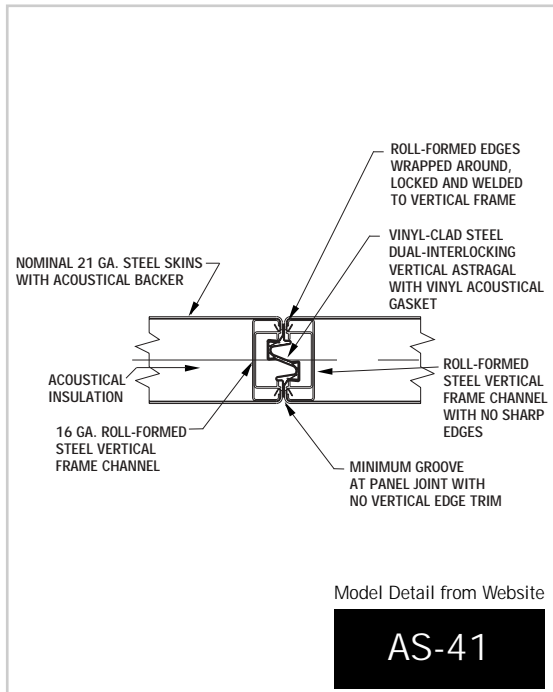

Standard Hinged Panel Joint

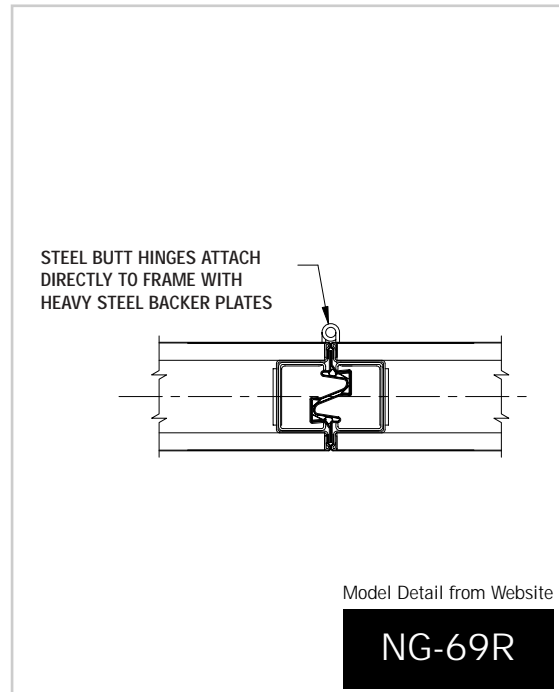

ACOUSTI-SEAL® 900 SERIES TECHNICAL DATA PANEL CROSS SECTIONS

Nominal Fixed Jamb

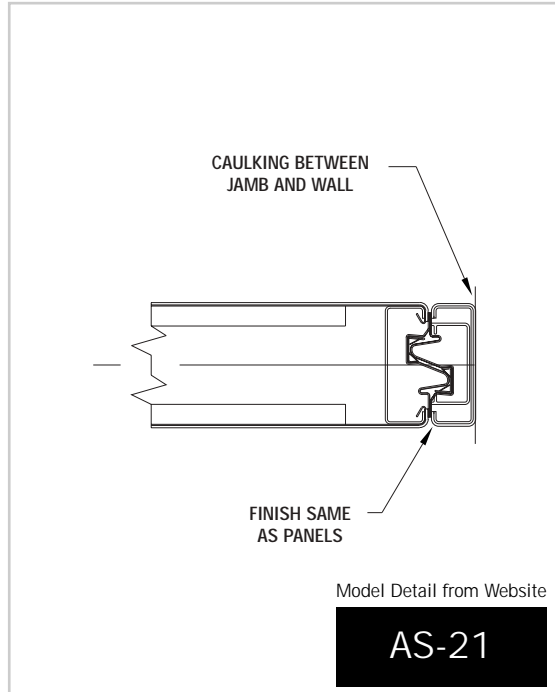

Variable Fixed Jamb

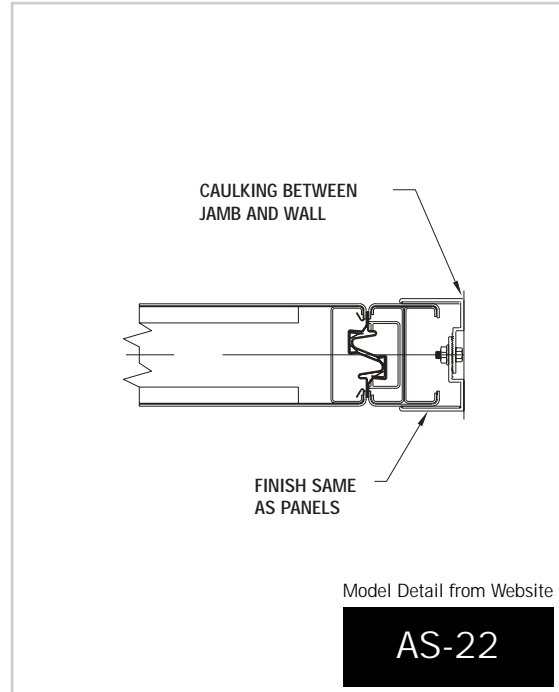

Bulb Seal and Intersection

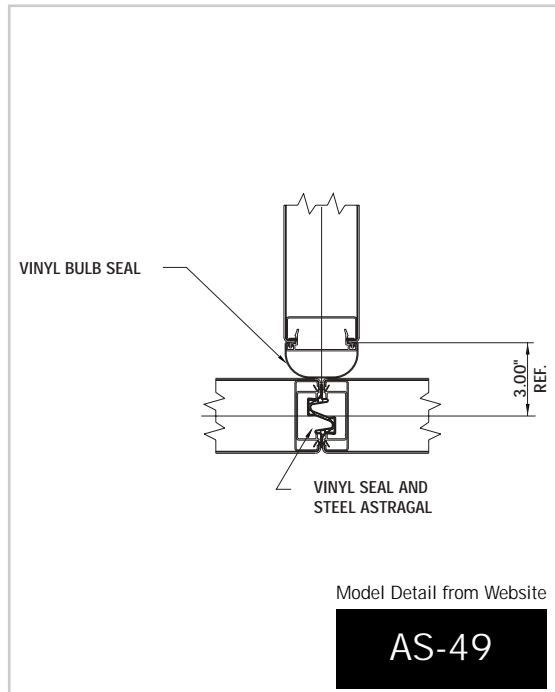

Modernfold, Inc.

Toll Free: 800.869.9685
www.modernfold.com
email: info@modernfold.com

A DORMA Group Company
www.dorma-usa.com